



SARGENT & GREENLEAF, INC.

1 SECURITY DRIVE • NICHOLASVILLE, KENTUCKY 40356

TELEPHONE: (606) 885-9411

TELEX: 21-8459

OPERATING AND CHANGING INSTRUCTIONS

REGULAR CHANGE – 4 WHEEL

Lock Models: 6435---6530---6535

Before operating the lock or changing the combination, READ THESE INSTRUCTIONS THOROUGHLY.

At the top of the dial ring an index is provided for normal dialing and opening.

This is a precision lock, therefore extreme care must be used to align the combination numbers with the index.

Turn the dial slowly and steadily. If, after turning the correct number of revolutions, the desired number is turned beyond the index mark, the entire series of combination numbers must be redialed. **DO NOT TURN BACK TO REGAIN A PROPER ALIGNMENT WITH THE NUMBER.** Each time a selected number is aligned with the index, a revolution is counted.

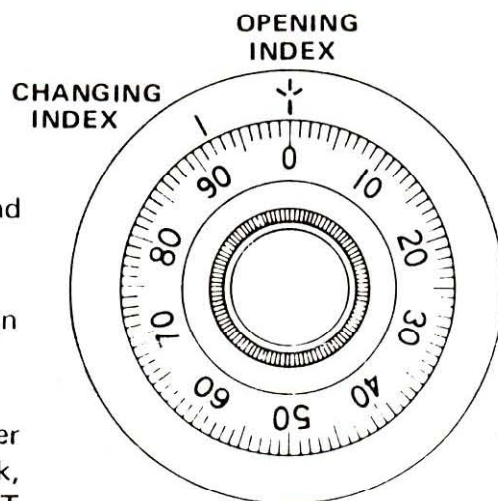

Figure 1.

TO UNLOCK ON A FACTORY SETTING

TO UNLOCK ON FACTORY SETTING- TURN DIAL "LEFT" 5 TURNS STOPPING ON "50". TURN DIAL RIGHT UNTIL BOLT RETRACTS.

TO UNLOCK ON A 4 NUMBER COMBINATION - For Example 10-20-30-40

Reverse dial directions (i.e. turn left instead of right for step 1) for left hand locks.

1. Turn dial to the **RIGHT**, stopping when "10" is aligned with the index, the **FIFTH** time.
2. Turn dial to the **LEFT**, stopping when "20" is aligned with the index, the **FOURTH** time.
3. Turn dial to the **RIGHT**, stopping when "30" is aligned with the index, the **THIRD** time.
4. Turn dial to the **LEFT**, stopping when "40" is aligned with the index, the **SECOND** time.
5. Turn dial slowly to the **RIGHT** until it stops.

TO LOCK

Turn dial to the **LEFT** at least five full revolutions.

CHANGING TO A NEW COMBINATION

Make up a new combination, selecting 4 sets of numbers of your own choosing. DO NOT use numbers between 0 and 20 for your last number. (e.g. 28-34-76-12). For maximum security DO NOT use numbers ending in 0 or 5 and DO NOT use numbers in a rising or falling sequence. e.g. 35-50-75-85 is not as good a combination as 54-38-72-27.

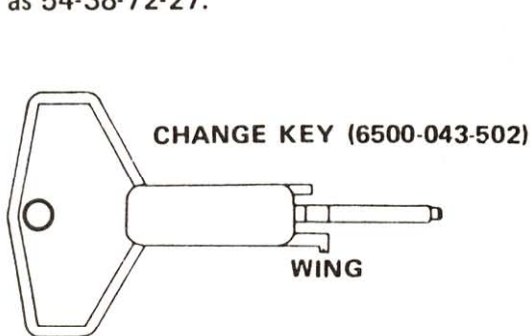

Figure 2.

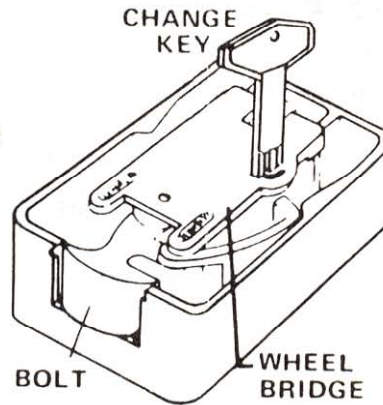

Figure 3.



Figure 4.

1. Remove cover screw, slide cover toward lock bolt and remove cover. Dial the existing combination as explained in paragraphs 1 thru 4 on changing index. Leave dial set at last number of combination.
2. Hold the dial with the last number at the index and insert the changing key (figure 2) in the appropriate hole in the back of the lock (figure 3) until the wing is entirely inside the lock and comes to a positive stop. (See figure 4.) Note: right hand and left hand locks have their respective change key holes.

CAUTION: Bolt should be in an extended position when turning change key.

3. Turn key one quarter to the LEFT. With the changing key in this position, dial the new combination of your selection as in paragraphs 1 thru 4 using the changing index.
4. Holding the dial with the last number aligned with the index, turn the changing key to the RIGHT and remove. The new combination you have selected is now set in the lock.

BEFORE CLOSING THE CABINET, try the new combination several times.

IF AN ERROR HAS BEEN MADE IN SETTING A NEW COMBINATION, we suggest that an accredited locksmith be called.